

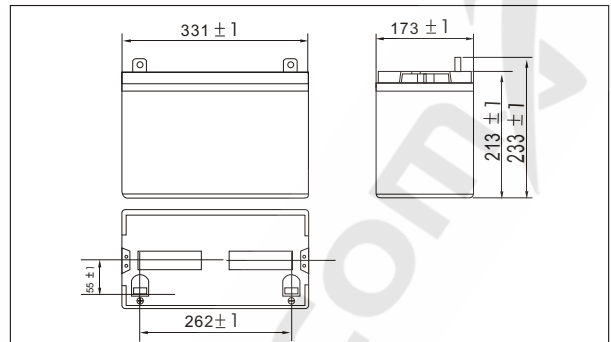

SW121000 (12V100AH)



● Outer dimensions (mm)



● Specifications

Nominal Voltage		12V
Rated capacity (10 hour rate)		100 Ah
Dimensions	Total Height	233 mm (9.17 inches)
	Height	213 mm (8.39 inches)
	Length	331 mm (13.03 inches)
	Width	173 mm (6.81 inches)
Weight Approx		30Kg (70.5lbs)

● Terminal Type (mm)

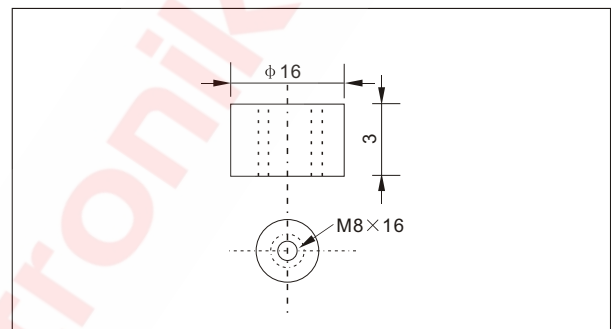

● Characteristics

Capacity 25°C(77°F)	10 hour rate(10A)	100 AH
	5 hour rate(16A)	80AH
	1 hour rate(60A)	60 AH
	1.5 hour discharge to 10.5V	40 A
Internal Resistance	Full charged Battery at 25°C(77°F)	3 mΩ
Capacity affected by Temperature (10hour rate)	40°C(104°F)	102%
	25°C(77°F)	100%
	0°C(32°F)	85%
	-15°C(5°F)	65%
Self-Discharge at 25°C(77°F)	Capacity after 3 month storage	91%
	Capacity after 6 month storage	82%
	Capacity after 12 month storage	64%
Terminal	T10	
Charge (constant Voltage)	Cycle	Initial Charging Current less than 40 A Voltage 14.10-14.40V
	Float	Voltage 13.50-13.80V

● Discharge Curves 25°C(77°F)

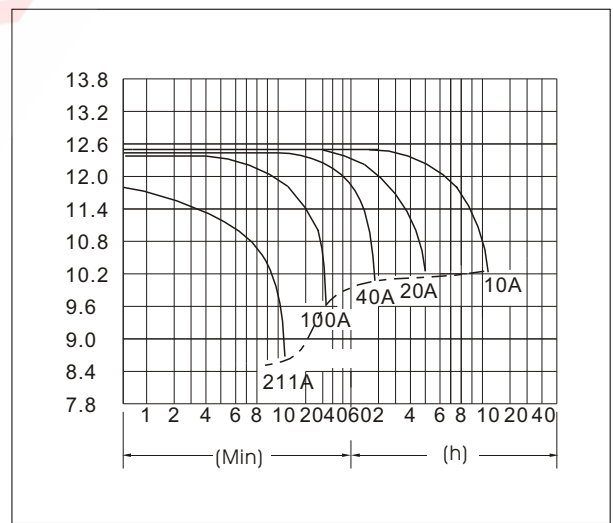

Constant Current(Amp) and Constant Power(Watt) Discharge Table at 25°C(77°F)

Time		5min	10min	15min	30min	1h	2h	3h	4h	5h	8h	10h	20h
9.60V	A	320	211	170	114.0	60.0	35.0	25.7	20.0	16.5	11.70	10.50	5.67
	W	3305	2253	1824	1226	648	384	286	225	188	134	121	65.9
10.20V	A	310	190	160	109.0	56.4	33.4	25.0	19.5	16.2	11.40	10.30	5.50
	W	3313	2126	1793	1224	638	385	290	227	189	133	121	64.5
10.50V	A	300	170	140	102.0	54.6	32.6	24.4	19.2	16.0	11.30	10.10	5.50
	W	3277	1937	1599	1174	632	378	284	225	188	133	120	65.0
10.80V	A	289	161	130	94.0	52.8	31.8	23.8	18.9	15.6	11.00	10.00	5.40
	W	3245	1851	1500	1089	615	372	281	223	184	130	119	64.3
11.10V	A	280	150	120	84.0	51.0	31.0	23.0	18.4	15.2	10.70	9.50	5.10
	W	3170	1742	1399	983	600	366	273	219	181	128	114.7	61.8