

**1、SCOPE**

This specification governs the performance of the following ORN Nickel-Metal Hydride cylindrical cell and its stack-up battery.

ORN Model : AAA 800

Cell Size: AAAcusp(10.1±0.1×44.0±0.5)mm

AAAcrow cut(10.0±0.1×43.5±0.5)mm

**2、DATA OF STACK UP BATTERIES**

All data involve voltage and weight of stack-up batteries are equal to the value of unit cell multiplied by the number of unit cell which consisted in the stack-up batteries

Example : Stack-up batteries consisting three unit cells

Nominal voltage of unit cell=1.2V

Nominal voltage of stack-up batteries =1.2V×3=3.6V

**3、RATINGS**

Description	Unit	Specification	Condition
Nominal Voltage	V/cell	1.2	Unit cell or stack-up batteries
Minimum Capacity	mAh	750	Standard Charge/Discharge
Nominal Capacity	mAh	800	Standard Charge/Discharge
Standard Charge	mA	80 (0.1C)	T <sub>1</sub> =20±5°C (See Note 1)
	hour	14~16	
Fast Charge	mA	160 (0.2C)	- ΔV=0~5mV/cell , Timer Cutoff=120%nominal capacity , Temp.Cutoff=55°C, dT/dt=0.8°C/min, T <sub>1</sub> =20±5°C
	hour	6 approx (See Note 2)	
Trickle Charge	mA	(0.03C)~(0.05C)	T <sub>1</sub> =20±5°C
Standard discharge	mA	160 (0.2C)	T <sub>1</sub> = 20±5°C Humidity: Max.85%
Discharge Cut-off Voltage	V/cell	1.0	
Storage Temperature	°C	-20~25	Within 1 year*
		-20~35	Within 6 months
		-20~45	Within 1 month
		-20~55	Within 1 week
Typical Weight	Gram	12.7	unit cell

\*To keep the best performance for those not used for a long time, we recommend to charge the cells/batteries at least 30% after discharge entirely in every 6 months.

ORN reserves the right to alter or amend the design, model and specification without prior notice.

**4、 PERFORMANCE**

Unless otherwise stated, tests should be done within one month of delivery under the following conditions:

Ambient Temperature : 20±5°C

Relative Humidity : 65±20%

Notes: Standard Charge/Discharge conditions:

Charge: 80 mA(0.1C)× 14 hours

Discharge: 160 mA(0.2C) to 1.0V/cell

Test	Unit	Specification	Condition	Remarks
Capacity	mAh	≥ 750	Standard Charge/ Discharge	up to 3 cycles are allowed
Open Circuit Voltage(OCV)	V	≥ 1.25	Within 1 hour after standard charge	
Internal Impedance	mΩ	≤ 40	Upon fully charged(1KHz)	
High Rate Discharge(1C)	min	≥ 51	Standard Charge, 1 hour rest before discharge by 1C to 1.0V/cell	up to 3 cycles are allowed
Charge Retention	mAh	≥ 480 (60%)	Standard Charge,Storage: 28 days Standard Discharge	T <sub>1</sub> =20±5°C
IEC Cycle Life	Cycle	≥500	IEC61951-2(2003)7.4.1.1	see Note 3
Leakage		No leakage nor deformation	Fully charged at : 80 mA for 48 hrs	
Vibration Resistance		Change of voltage should be less than 0.02V/cell,Change of impedance should be less than 5 milli-ohm/cell	Charge the battery at 0.1C for 14hrs,then leave for 24hrs,check battery before/after vibration,amplitude 1.5mm,vibration 3000 CPM,any direction for 60mins.	
Impact Resistance		Change of voltage should be less than 0.02V/cell,change of impedance should be less than 5 milli-ohm/cell	Charge the battery at 0.1C for 14hrs,then leave for 24hrs,check battery before/after dropped,height 50 cm wooden board(thickness 30mm)direction not specified,3 times.	

ORN reserves the right to alter or amend the design, model and specification without prior notice.

**5、 CONFIGURATION, DIMENSIONS AND MARKINGS**

Please refer to the attached drawing.

**6、 EXTERNAL APPEARANCE**

The cell/battery shall be free from cracks, scars, breakage, rust, discoloration, leakage or deformation.

**7、 WARRANTY**

One year limited warranty against workmanship and material defects.

**8、 CAUTION**

[1] Reverse charging is not acceptable.

[2] Charge before use. The cells/batteries are delivered in an uncharged state.

[3] Do not charge/discharge with more than our specified current.

[4] Do not short circuit the cell/battery Permanent damage to the cells/batteries may result.

[5] Do not incinerate or mutilate the cells/batteries.

[6] Do not solder directly to the cells/batteries.

[7] The expected life may be reduced if the cells/batteries are subjected to adverse conditions as:  
extreme temperature, deep cycling, excessive overcharge/ over-discharge.

[8] Store the cells/batteries in a cool dry place. Always discharge batteries before packing.

**Notes:**

[1]  $T_1$ : Ambient Temperature.

[2] Approximate charge time from discharged state, for reference only.

Cycle No.	Charge	Rest	Discharge
1	$0.1C \times 16h$	None	$0.25C \times 2h20min$
2-48	$0.25C \times 3h10min$	None	$0.25C \times 2h20min$
49	$0.25C \times 3h10min$	None	$0.25C$ to 1.0V/cell
50	$0.1C \times 16h$	1-4h	$0.2C$ to 1.0V/cell

Cycle 1 to 50 shall be repeated until the discharge duration on any 50th cycle becomes less than 3 h.

ORN reserves the right to alter or amend the design, model and specification without prior notice.

**MODEL No:** ORN-AAA800

**Description:** 800 mAh SIZE NI-MH AAA

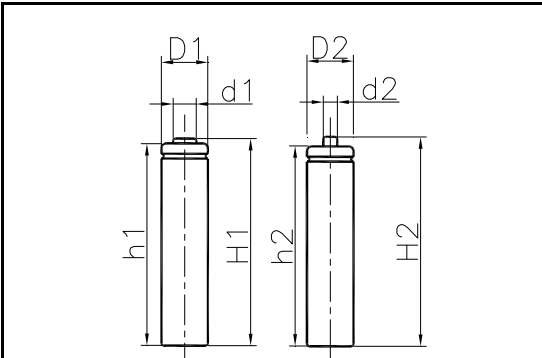

Dimensions(without Tube) (mm)

D <sub>1</sub>	10.00±0.10	D <sub>2</sub>	10.10±0.10
d <sub>1</sub>	5.10±0.08	d <sub>2</sub>	3.70±0.08
H <sub>1</sub>	43.50±0.50	H <sub>2</sub>	44.00±0.50
h <sub>1</sub>	43.00±0.50	h <sub>2</sub>	42.00±0.50

**Specification**

Nominal Capacity		800 mAh
Nominal Voltage		1.2 V
Charge current	Standard	80 mA
	Fast	160 mA
Charge time	Standard	14~16 Hrs
	Fast	6 Hrs
Ambient Temperature	Charge	Standard 0°C~45°C Fast 10°C~45°C
	Discharge	-20°C~60°C
	Storage	-20°C~55°C
Internal Impedance(mΩ) (After Charge)		≤ 40
Weight		12.7 g

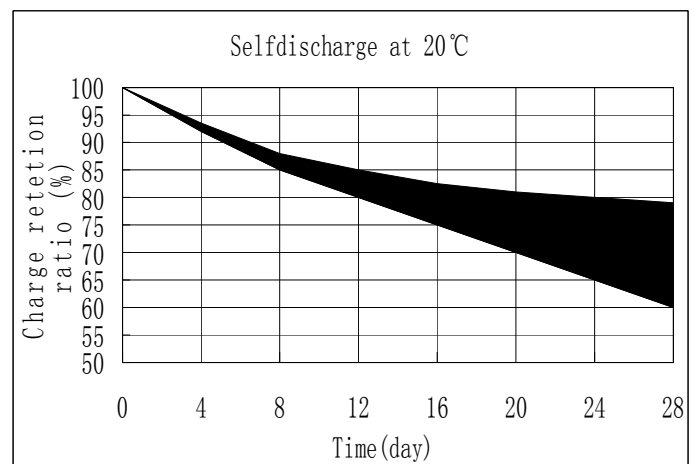
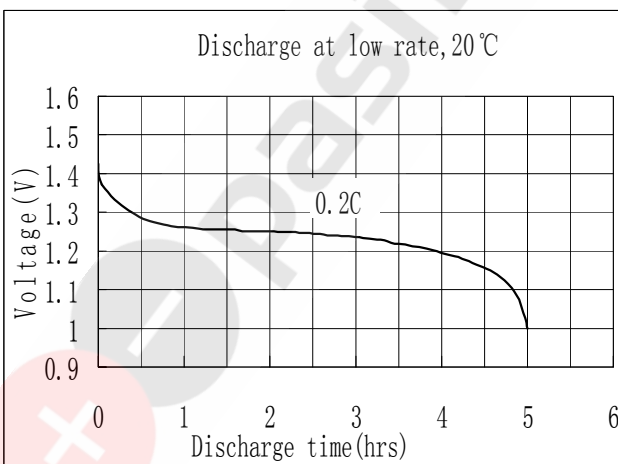
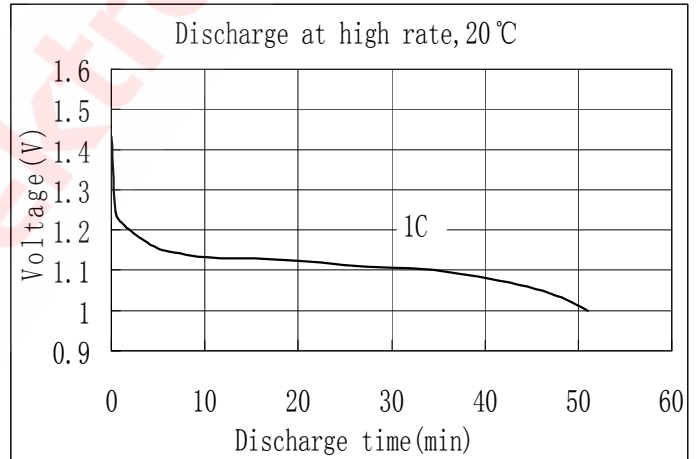
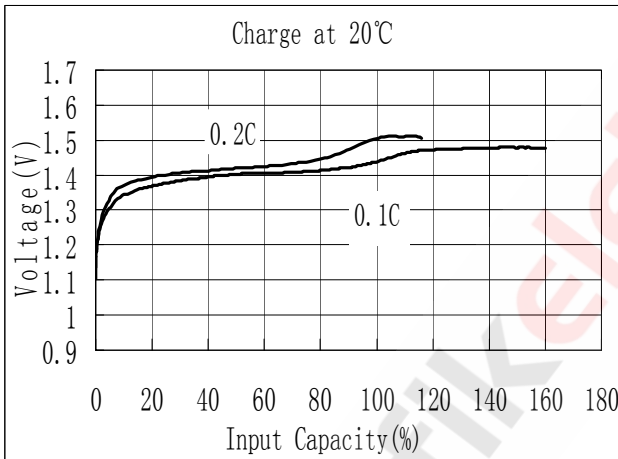

ORN reserves the right to alter or amend the design, model and specification without prior notice.